

**Adopting Circuit Breakers for High Voltage DC networks.
Appropriating the vast advantages of DC transmission grids**

Dragan Jovicic University of Aberdeen d.jovicic@abdn.ac.uk	Guangfu Tang State Grid Corporation of China gftang@geiri.sgcc.com.cn	Hui Pang Global Energy Interconnection Research Institute panghui@geiri.sgcc.com.cn
--	---	--

1 Introduction

AC (Alternating Current) power transmission systems have been used since the late 19th Century as a universal method of interconnecting multiple power producing plants with load centers. Highly meshed AC transmission grids with high redundancy and operating flexibility have been built worldwide. These complex AC systems have provided high power availability and security, while multiple voltage levels facilitate reduction in losses.

In addition to transmission lines, there are two key components which are essential for building transmission systems: circuit breakers (CBs) and transformers. These two components can be fabricated as relatively simple, reliable, and efficient units when AC transmission is used. Circuit breakers enable opening a circuit (line) under load and fault currents, which is essential for regular maintenance, system expansion, and the physical integrity of large transmission systems. Transformers facilitate voltage level change, which is necessary for safety and reliability, but also for reducing losses with long distance transmission.

The shortcomings of AC transmission are numerous, and have been publically debated since the time of “war of the currents” between Tesla and Westinghouse on one side and Edison on the other. In particular, AC transmission implies reactive current transfers, which increase losses and cause operating difficulties. With subsea cable transmission at distances over *50-100km*, reactive power issues become severe caused by excessive line charging and AC transmission is not practically feasible.

HVDC (High Voltage Direct Current) transmission has been used since 1954, but it has experienced substantial technological advances and increased application in the last 20 years. The technology is facilitated by high-power electronic devices including thyristors and more recently transistors, which enabled development of more compact VSC (Voltage Source Converters). The vast majority of HVDC systems consist of a single line or cable and use one AC/DC converter at each end. It has not been possible to directly connect multiple DC lines in a network, primarily because of lack of suitable DC (Direct Current) circuit breakers. Nevertheless, in the last 5 years, two multiterminal VSC HVDC systems have been built in China, and others are under design and development.

DC transmission grids represent a substantial technological advance over point-to-point HVDC connections, and they are under investigation for many applications worldwide. In Europe, researchers in several major EU projects studied a North Sea cable DC grid as the means for integrating large amounts of offshore wind energy and strengthening interconnections between EU countries. In China, there are firm plans for building a 4-terminal DC grid with overhead lines.

The facilitation of DC grids requires the market availability of a DC Circuit Breaker, preferably from multiple vendors that all offer acceptable performance, cost, size, losses and reliability. Much has been learned from long experience with AC Circuit Breaker technologies, which are standardised at high voltage and very high current ratings. However, they are not suitable for DC applications, and the technologies for DC CBs will be substantially different from AC CBs. The performance requirements for DC CBs in DC grids are more stringent, while DC circuit opening is also technically much more challenging.

In the last 5-10 years some major advances have been made developing High Voltage DC CB technologies. Multiple DC CB topologies have been demonstrated in laboratories and brought to the market, with the first installations having emerged in recent years.

2 Basic Performance Requirements for DC Circuit Breakers

2.1 The role of DC CBs

The critical functions of DC CBs include controlled opening/closing of circuits and in case of faults isolating faulted DC lines, which are necessary to enable continued operation of the remaining portion of the DC network. If the faulted line were not isolated, grid voltage would be low and currents would be high under the fault condition. High current would likely lead to component damage while low voltage would reduce power transfer capability. Fast DC fault isolation is particularly significant for large DC grids, which may have numerous converter stations and transmission lines. The converters considered for

the European North Sea DC grid are rated at 1.5-2 GW, while the total DC Grid capacity may exceed 150 GW in some scenarios.

Figure 1 shows a single line diagram of a 5-node ± 400 kV DC grid, which consists of 4 AC/DC bi-pole converters rated 800 MVA, 2kA per pole interconnecting the DC grid (busses 1-4) with corresponding AC systems, one DC bus without a converter (node 5), 8 DC cables and 16 DC CBs per pole (32 DC CBs in total). The grid topology has been selected as an illustrative example that provides reasonable power transfer security while trying to limit the number of DC CBs. In comparable AC systems, considering modern grid development practices, the number of AC CB would be much higher. The indicated power and voltage levels are in the highest range of demonstrated DC CB technology.

For example, a short circuit fault occurring on line 3-4 would insert a low impedance at the point of fault and result in high currents flowing into the fault from all parts of the network (as indicated by red arrows). Depending on the impedances of the grid cables and of the severity of the fault itself, the fault currents would have different magnitudes, but they can easily reach 10-30 times the rated current (say 20-60 kA) at some points. These are destructive currents which grid components cannot withstand.

All high-power AC/DC converters have self-protection control logic, which blocks and disconnects converters in the event of disturbances. Typically, self-protection thresholds are set at approximately 2 pu current and 0.8 pu DC voltage, which for the considered system implies 4 kA current and a 320 kV voltage.

In conventional AC transmission systems, generators have numerous self-protection controls, but the thresholds are significantly higher relative to the nameplate rated variables. The line/cable impedances also have much higher values in AC than DC systems because the frequency, f , contributes to the reactance (the imaginary part of the impedance, $2\pi fL$, where L is the inductance).

These factors lead to the conclusion that in a DC system CBs (and protection system) must respond much faster than in AC systems, in order to prevent widespread loss in capacity (converter blocking) and destructive fault current magnitudes.

2.2 Operating speed

In a DC fault situation, current rises, and voltage falls throughout the DC grid during the delays associated with DC protection and DC CB operation. Once the DC CBs open and isolate the DC fault, the DC voltage recovers and DC power flows over the reconfigured grid at a newly established balance operating point, which depends on the number of remaining operating converters and their control strategies. The faster the DC CBs operate, the less the DC fault adversely affects the DC grid.

However, the blocking of nearby converters cannot be completely avoided even with application of the fastest available DC CBs. This is because the converters closest to the fault point may experience high current and thus block prior to the DC CBs opening. The most recent DC grid studies indicate that temporary converter blocking for 10-30 ms is possible until the DC fault is cleared and the converters can then be de-blocked to resume normal operation. The need for blocking converters will depend on the grid topology and the fault location.

Many studies indicate that DC grids of various sizes and topologies can recover from any DC line fault if the total protection time (DC CB opening time plus protection operation time) is within approximately 10ms. This assumes that some converters may block by self-protection temporarily or permanently, depending on the grid topology and the strategy used for protecting the network. Permanent blocking after fault clearing occurs if the converter becomes isolated, and results in loss of grid capacity.

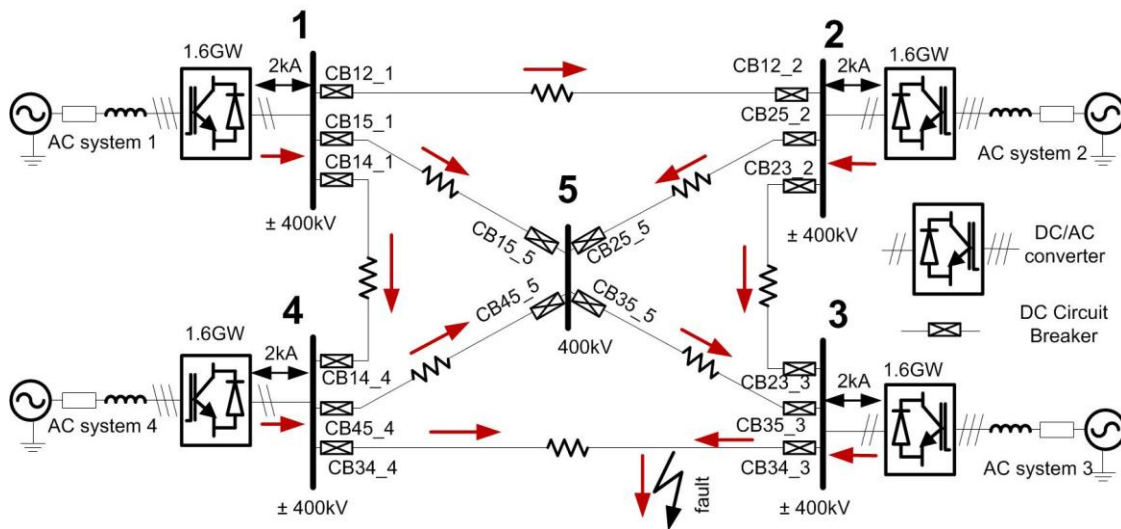

Figure 1. 5-Node DC grid with 4 AC/DC converters, 8 DCcables and 16 DC CBs per pole.

2.3 Ratings

In AC systems AC CBs are rated for the largest available fault level at their point of connection (the worst case steady-state fault current). The cost and technology status of DC CBs restrict their peak fault current ratings, as shown by designs of DC CB prototypes recently brought to the market by manufacturers, which are designed for only $15\text{-}20\text{kA}$ peak interrupting current. These state-of-the-art DC CBs have lower ratings than expected available fault levels at most DC busses for the foreseeable future. Thus, DC CBs are required to operate fast, before DC fault current exceeds their ratings, and before it reaches destructive levels causing many converters to block and a resultant wider DC grid voltage collapse.

2.4 Bidirectional operation

In many applications, DC CBs will be expected to interrupt fault current in one direction only. Depending how protection zones and protection system are configured, some DC CBs may be expected to operate in both directions. Also, bidirectional operation may be beneficial as a back-up protection function when needed. Application of a unidirectional DC CB may suffice in particular projects and result in substantial cost and size savings for some DC CB topologies.

2.5 Multiple Open/Close operations in short time

DC Grids with overhead lines would be exposed to frequent faults, many of which would be transient. As with overhead AC transmission, reclosing with multiple CB operations within $200\text{-}500\text{ms}$ may reasonably be expected. With underground or underwater DC cable systems, however, almost all faults are permanent and reclosing may not be included in the protection logic. The number of expected operations and timing of DC CB duty cycles may result in cost and size implications for some DC CB topologies.

2.6 Losses, size and weight

DC CBs operate in a closed state and conduct load current most the time. Closed-state losses in DC CBs reduce revenue to their grid operators, and the DC CBs also require additional heat removal equipment.

DC CBs will be noticeably larger and heavier than AC CBs. In Europe, DC grid studies of offshore environments show that DC CB size and weight could have significant implications for platform costs.

2.7 Cost and reliability

The ubiquitous application of AC CBs to AC transmission systems facilitates high degrees of power supply security and operating flexibility. The simple DC system in Figure 1 has an elementary protection strategy but requires 32 DC CBs in total. The example shows applications for a considerable number of

DC CBs in future grids would be anticipated. DC CB costs will be higher than AC CBs, and for some DC CB topologies perhaps substantially higher than AC CB costs.

The internal complexity of DC CBs requires further study of their failure modes to fully understand their reliability considering that operational experience is minimal. Some DC CBs using semiconductor technologies have self-protection as discussed below, which needs to be considered by grid planners and protection system developers.

2.8 Standardisation of inputs/outputs

In large DC grids, the protection system will consist of multiple relays (microcontroller-based), which are interconnected and use adjusted settings controlled by the grid operator. Grid topology changes and expandability must be considered as important factors developing protection logic. Achieving desired relay commands with components made by different vendors requires standardization of interconnections and interoperability as important DC CB requirements.

3 Challenges with DC circuit opening

3.1 DC current commutation

The first developers of DC systems learned that interrupting DC current is difficult. Trying to separate CB contacts under a current flow creates an arc, which for high voltage systems is self-sustaining and generates large amounts of heat caused by the arc resistance. With AC currents, there is a natural current zero crossing twice every cycle (every 10 ms in 50 Hz systems). This momentary current interruption, with the aid of engineering devices that ensure sufficient contact separation and an arc extinguishing chamber, enables modern AC CBs to reliably interrupt very large currents within $20\text{-}60\text{ ms}$.

There are no natural current zero crossings in DC systems. At low voltages of $10\text{-}30\text{ V}$ (automotive applications) the arc voltage is larger than the system voltage and this reduces the current to zero. At higher voltages there are two principal methods to interrupt DC current:

- 1) Use power electronics to commutate current into a parallel circuit. Semiconductors provide solid insulation, and can interrupt large currents very quickly and without arcing. The principal challenges are large component costs and high losses during normal closed-state operation.
- 2) Using additional circuits, such as commonly used LC resonant systems, to create current zero-crossings in mechanical switches. Mechanical switches have practically negligible closed-state losses and generally have low weight, size, and cost at high voltage ratings. The foremost challenge is arcing, which implies heavier and more complex contacts necessary for successful operation that in turn leads to slower opening speeds.

Both methods are viable and have been demonstrated on high voltage and large current DC CB units.

3.2 DC current reduction and dissipation of energy

The energy dissipation in a device is the product of the current and voltage across the device, multiplied by time. With AC CBs there is minimal dissipation of energy because the contacts open when the load current crosses zero. Any energy in the system is conveniently dissipated in the arc chamber.

With DC CBs, the moment of interruption occurs for a large value of DC load current that is reduced for interruption by inserting a larger counter DC voltage, usually by the means of non-linear resistors (surge arresters). An integral part of all DC CBs, these resistors are also called energy absorbers because they need to absorb the energy from the line inductances and thus experience high voltage and high current for a short period until the DC current is brought to zero. The expected energy dissipation at a 400 kV DC voltage level is on the order of $10\text{-}100\text{ MJ}$ that affects the thermal ratings and time constants of the absorbers, which is especially important if repeated DC CB operations are required. This degree of energy dissipation also influences the DC CB cost, size, and weight.

3.3 Series inductor with DC Circuit Breakers

Each DC CB in HVDC grids requires use of a series inductor on the order of $50\text{-}300\text{ mH}$. Although this inductor cannot reduce the amplitude of the DC fault current, it can limit the rate or rise of the fault current. Sized for a given protection and DC CB operating times, this inductor limits the peak fault current that is experienced by DC CBs and other components in the DC grid. For example, a 400 kV DC bus with a desired interrupt time (DC CB opening and protection time) of 4 ms and with a maximum peak interrupting current of 16 kA requires inductor of around 100mH .

Installation of series inductors with DC CBs also facilitate DC grid protection system selectivity, i.e. they enable the protection system to differentiate between faults in inner and outer protective zones.

Because of these multiple requirements for the series inductor, it is not clear if the series inductor will be considered as part of future DC CB units, or if it will be regarded as a part of the DC protection system.

On the negative side, series inductors store energy and negatively influence voltage control of DC grids. In addition, the energy stored in the inductor must be dissipated by DC CBs in the event of fault interruption.

4 Main DC CB topologies

Several manufacturers have invested substantially in further developing DC CBs to high technology readiness levels. These manufacturers have reported results from laboratory tests of DC CB prototypes in the range of $40\text{-}80\text{ kV}$ with peak fault current interruption capabilities of approximately $15\text{-}20\text{ kA}$. Plans call for these units to become standard modules through series connections to achieve higher DC voltage levels. The communications from manufacturers and data from recent installations indicate that there are no substantial obstacles to implement $300\text{-}400\text{ kV}$ DC CBs.

The European Union has directed substantial resources towards understanding DC CBs, including tests of several full-scale ($70\text{-}80\text{ kV}$) DC CBs at an independent laboratory. There is joint effort by multiple manufacturers, grid operators, academia, and consultants substantially contributes towards acceptance of DC CBs by advancing the understanding of their control, operating limits, testing, failure modes, and interactions with DC grid components. Considerable further effort is being directed toward achieving interoperability among various DC CB technologies and different manufacturers, and to initiate standardisation.

Many different DC CB topologies discussed in research papers have been proposed, with some prototypes of varying ratings undergoing field tests. Many new patents related to DC CBs have emerged recently, and intensive research will continue in this field.

It is possible to group most DC CB designs into two main families: 1) mechanical DC CBs and 2) hybrid DC CBs using semiconductor valves. The typical designs from each family will be presented below for illustration purposes, without reference to any particular manufacturer.

5 Mechanical DC Circuit Breaker

5.1 Topology

Figure 2 shows a typical topology of a mechanical HVDC circuit breaker. It consists of the following:

- 1) Main branch consisting of a breaker which is able to sustain arcing. Commonly this is an AC VI (Vacuum Interrupter) with an enhanced driving mechanism to reduce opening time.
- 2) Current injection branches with pre-charged capacitors. Two branches are shown, which enable two operations in a short period of time, considering that capacitor charging may take a long time. The second branch is not needed if the required breaker duty cycle consists of only a single opening. Switches VI3a and VI3b are similar to VI1. The natural resonant frequency of the LC circuit can be increased to practical values approximating $2\text{-}3\text{ kHz}$ that would reduce the required sizes of L_1 and C_1 . The resistors R_1 are required for capacitor charging.
- 3) Energy absorber which consists of banks of surge arresters. These arresters are based on standard surge arresters widely used in AC systems for overvoltage protection.

- 4) Residual breaker, VI2, which interrupts only a small current, and where opening speed is not critical.
- 5) L_{dc} is a current limiting inductor that reduces the rate of rise of fault current.

The mechanical DC CB presented is also called a current injection DC CB, since it employs pre-charged capacitors, C_{1a} and C_{1b} , which substantially improve the speed of each operation.

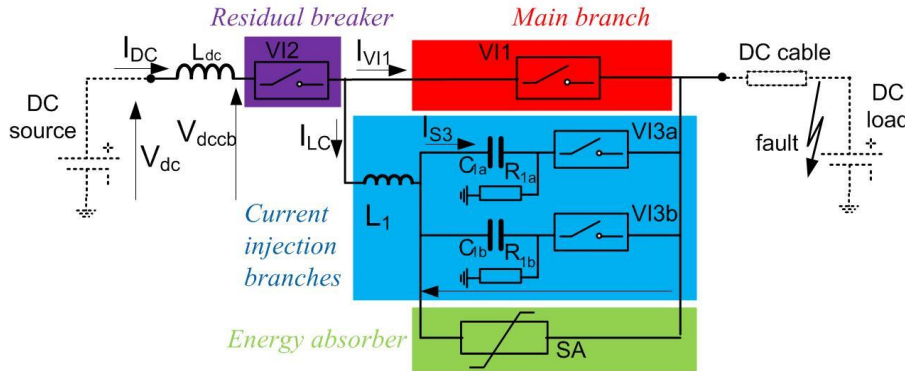

Figure 2. Mechanical DC Circuit Breaker.

5.2 Operating principles

Figure 3 illustrates interruption of $15kA$ peak DC fault current with a mechanical DC CB on a $400kV$ DC system, assuming a DC fault at $t=0s$. A series inductor of $L_{dc}=240mH$ is used. Figure 3A shows that it takes approximately $8ms$ for the VI1 contacts to fully separate, and at this instant VI3 closes, injecting an oscillating current, I_{S3} that facilitates a zero crossing of I_{VI1} . When the arc is interrupted in VI1, the DC current I_{DC} is transferred to the energy absorber and voltage V_{DCCB} abruptly rises to the clipping voltage of the surge arresters, which is commonly around $1.5pu$ ($600kV$). This high voltage brings a negative voltage across inductor L_{dc} ($400kV-600kV$), enabling fault current suppression. The fault current is fully extinguished after an additional $20ms$, as seen in Figure 3B.

Commonly, manufacturers will specify the time to voltage recovery ($8ms$ in Figure 3) as the key DC CB performance indicator. The peak fault current is specified as the single indicator of interrupting capability ($15kA$ in 0), which is a key parameter for sizing the series inductor L_{dc} , which could also vary for different DC CB technologies because of different opening speeds.

The expected energy dissipation by the arrestors in this case is around $E_{SA}=83MJ$, as seen in 0D. Figure 3 illustrates fault current interruption in the positive direction, but this DC CB topology can similarly interrupt DC fault current in the negative direction. However, since the charge of capacitor C_1 is unipolar, the responses in the negative direction will be slightly different and component stresses might be higher.

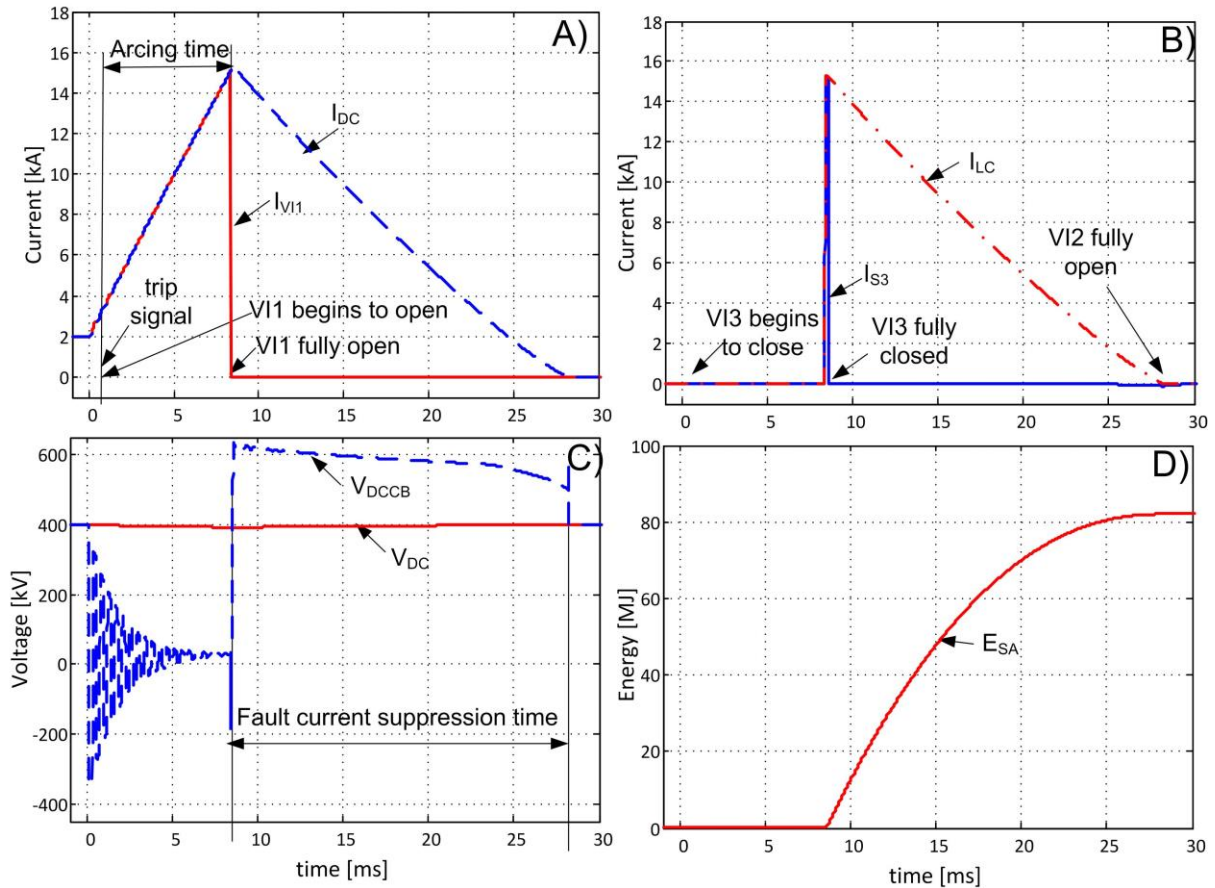

Figure 3 DC fault current interruption with 400kV, 16kA, 8ms Mechanical DC Circuit Breaker.

6 Hybrid DC Circuit Breaker

6.1 Topology

A representative topology for hybrid DC CB is shown in Figure 4. It consists of the following:

- 1) A Main Branch with two 400kV semiconductor valves T_{2A} and T_{2B} (one for each direction). If protection in only one direction is desired, then only one valve would be required. Each valve is similar to one arm of a (6-arm) VSC HVDC converter. This branch can conduct load current in a closed state, but losses would be high with prolonged operation.
- 2) The auxiliary branch, which has low resistance, conducts full load current in closed state. This branch includes:
 - a. A low-voltage semiconductor valve T_1 . This valve is also called the load commutation switch, and it should have a voltage rating comparable with the closed-state voltage drop of the valve T_2 (i.e. in the order of 10kV).
 - b. An ultrafast disconnect switch S_1 . This switch cannot support arcing (it can open only at zero current), but has an extremely fast opening speed. Significant technological advances have been made recently using Thomson coil drivers, and the opening speed for 320kV units has been demonstrated as approximately 2ms.
- 3) Energy absorber, SA, which consists of banks of surge arresters.
- 4) Residual breaker S_2 which interrupts only the arrester leakage current. Its opening speed is not critical.

L_{dc} is a current limiting inductor.

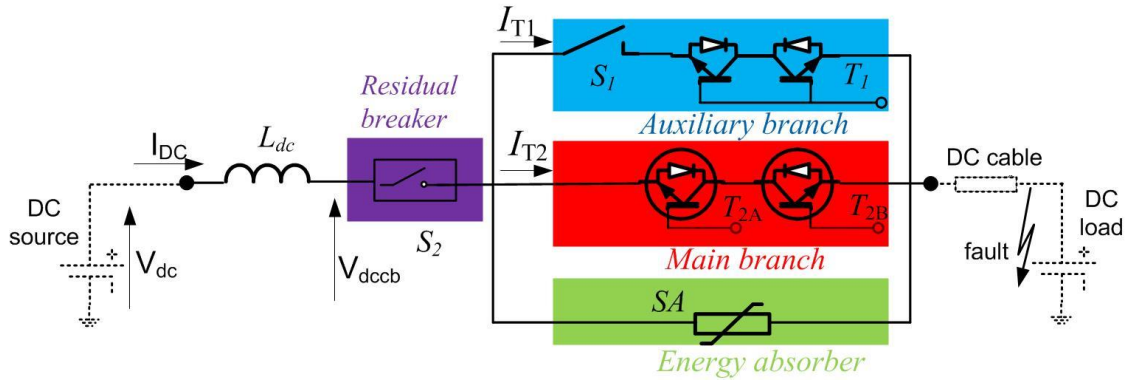

Figure 4 Hybrid DC Circuit Breaker.

The low voltage valve T1 continuously conducts load current, and it must withstand fault current in the period before the protection relay sends the trip signal. In practice, this valve consists of several parallel branches, with each branch having a few IGBTs (Insulated Gate Bipolar Transistors) in series. Because of the continuous conduction stress, this valve requires a forced liquid cooling system. The main valve T₂ only conducts the fault current for around 2ms and therefore it does not need liquid cooling. However, the whole hybrid DC CB should be located indoors (in a valve hall) similar to any large converter.

6.2 Operating principles

Figure 5 illustrates a DC fault on a 400 kV DC system interrupted by a hybrid DC CB that uses a series inductor of $L_{dc}=76\text{ mH}$. The fault occurs at $t=0\text{ s}$ and the current peaks at 15 kA. Figure 5B shows that S_1 begins to open when the current is transferred to T_2 and I_{T1} drops to zero. It takes 2ms for S_1 to fully open while T_2 is conducting. Once S_1 is open, the current is commutated to the energy absorber by opening T_2 . As current commutates to surge arresters, their voltage rises to 1.5 pu, which initiates current suppression. It takes another 5 ms for the fault current to reduce to zero, as seen in Figure 5A. Figure 5D illustrates that the expected total energy dissipation in this case is E_{SA} is equal to 21 MJ.

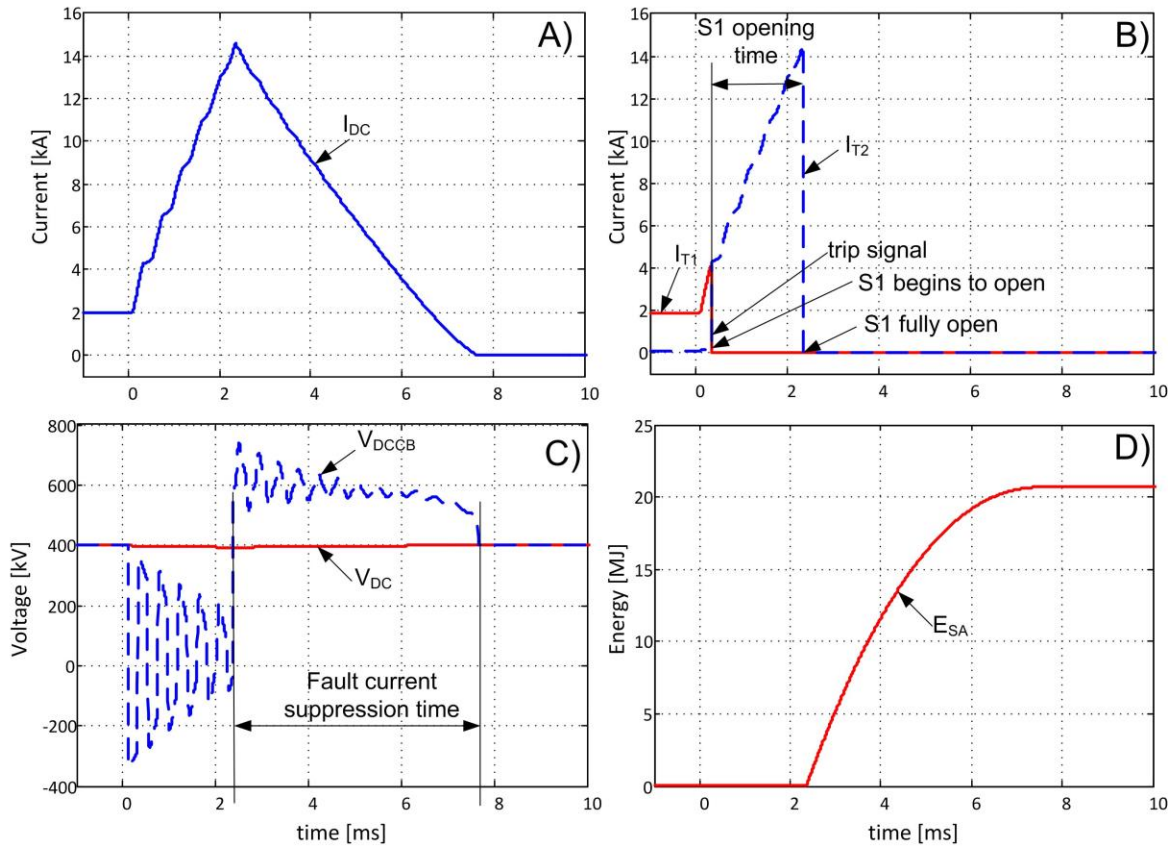

Figure 5. DC fault current interruption with 400kV, 16kA, 8ms Hybrid DC CB.

6.3 Self protection

Similar to all high-power converters, the semiconductor valves in hybrid DC CBs have self-protection that opens the valves in the event of excessive current. Although unlikely, a failure in some grid protection components (relay, sensor, communication, etc.) could fail to send a trip signal to the DC CB in a DC fault situation, which results in rising high DC CB current without a DC CB trip command. In practical terms this means that the DC CB may open on its own to protect itself at some DC current threshold (which is much higher than DC grid protection settings).

This function will have a largely positive connotation. If the DC grid protection were to fail for whatever reason, it can be expected that the hybrid DC CB would open at its self-protection threshold as the last line of defense.

6.4 Fault current limiting

Hybrid DC CBs can also act as DC fault current limiters. By employing ON/OFF control of the individual modules in the valve T_2 , the number of inserted arresters can be varied, which can regulate current. This operating mode is limited by the thermal capability of energy absorbers, and can most likely be achieved for only short periods of time.

This fault limiting operating mode can be beneficial in some applications, for example:

1. Limiting fault currents allows additional response time for fault clearing by other DC CBs installed on other lines in a DC grid. In practical terms, the DC CBs or protection systems on the other lines may have slower response times.
2. Limiting inrush currents when connecting DC lines eliminates the need for pre-insertion resistors on the DC CBs.

7 DC Circuit Breakers Installed in China

7.1 Installed hybrid DC CB in the Zhoushan multiterminal system

Among the islands of the Zhoushan archipelago, the largest power-consuming islands include the main island of Zhoushan, followed by the islands of Daishan, Qushan, Yangshan, and Sijiao. The annual load of the Zhoushan power grid reached 780 MW in 2010, and is estimated to reach 2000 MW in 2020 as a result of higher demand arising from economic development.

So, a ± 200 kV five-terminal VSC-HVDC project, constructed by the State Grid Corporation of China, began commercial operation in 2014. It transmits power from the mainland to the five islands. This project employ modular multi-level converter and connects by submarine cables. During normal operation, the Dinghai converter station on Zhoushan Island provides DC voltage control, and the other stations operate in power control modes. As a result, the power flows from Dinghai station to the others. Due to the lack of HVDC circuit breakers, clearing a DC fault was originally achieved by slow-acting AC system breaker operations. The lack of rapid fault isolation and ability to switch facilities caused several technical issues on the system, including the need for improved system security, operating flexibility, reliability, and rapid system restoration.

In 2016 a hybrid DC circuit breaker rated 200 kV was installed at Dinghai station on the Daishan to Daishan line, which improved the controllability and reliability of the Zhoushan project (see Figure 6).

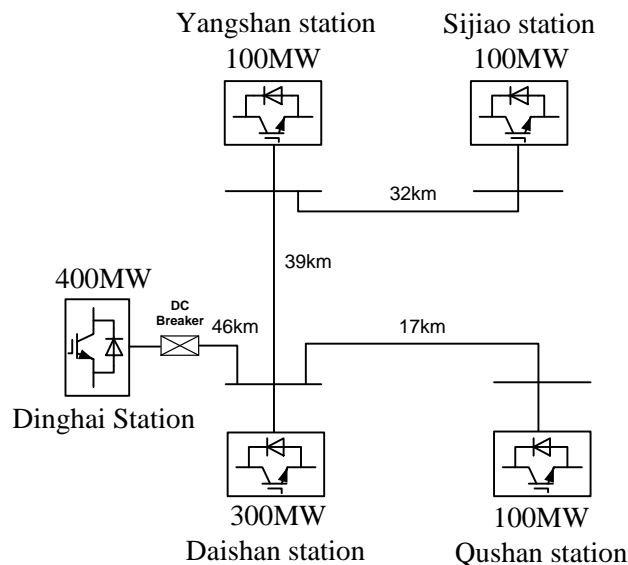

Figure 6. The Zhoushan 5-terminal HVDC transmission system with the installed hybrid DC CB

Figure 7 shows the topology and picture of a prototype of 200kV hybrid HVDC circuit breaker. The three branches consist of the following:

- 1) The Auxiliary branch carries nominal current and contains a series combination of an ultrafast mechanical disconnecter (UFD) and an auxiliary commutation switch, which consists of a full bridge sub-modular (FBSM) employing high power rating IGBTs. The FBSMs appearing in the auxiliary branch and main branch adopt the same full-bridge structure that consists of 4 press-pack IGBTs and a snubber circuit. The auxiliary branch should have as few FBSMs as possible to reduce the on-state impedance. Therefore, a matrix of 2×3 FBSM design is used, featuring low conduction losses and high reliability. As a means of facilitating maintenance, the design of each FBSM uses an integrated modular unit connected by an inductance-less busbar. A water-cooling system is needed because the auxiliary branch conducts the long-term load current. Since the UFD is opened with zero current, the mass of its inside contacts is reduced, and its driving mechanism is designed as a lightweight system. Therefore, compact design is achieved by employing a vacuum interrupter (VI) with voltage rating of 40.5 kV and current rating of 2 kA rather than an SF6 circuit breaker. The maximum separation time of the breaker must be within 2

ms to meet the fault clearance time requirements of the Zhoushan project. As a result, a series connection of 6 VI is adopted and each VI is equipped with voltage-sharing devices.

- 2) The main branch interrupts fault currents and consists of four series-connected modular units. Each modular unit contains 36 FBSMs in a series connection that is designed for 50 kV voltage and 15 kA current breaking capability. A cooling system is not necessary for the main branch because it only experiences the fault current for several milliseconds. The FBSM topology provides a bidirectional current path and allows for the hybrid circuit breaker to interrupt fault current in either direction. In addition, the capacitors in the FBSM enable soft turn-off of the IGBTs, significantly decreasing the induced voltage stress and balancing the voltage distribution across the modular unit during fault interruption.
- 3) The energy absorber branch is made up of surge arresters that limit transient interruption voltages (TIV) and dissipate the magnetic energy stored in the system.

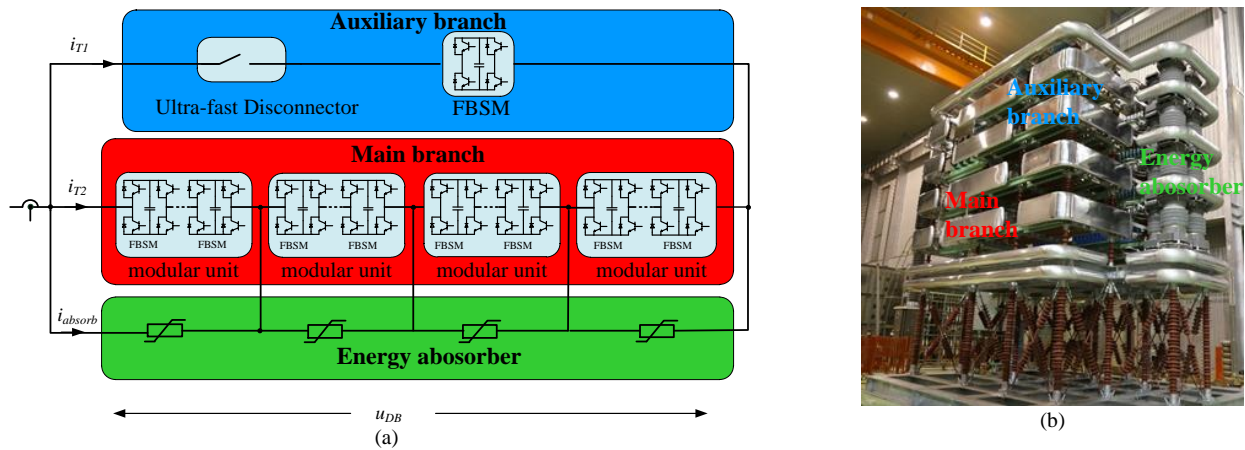

Figure 7. 200kV hybrid HVDC circuit breaker: (a) topology, and (b) prototype

The installed hybrid HVDC circuit breaker offers the following advantages:

- Small footprint and height resulting from the integrated and compact design (installed at a 200 kV high potential platform)
- Low power losses during normal operation resulting from use of fewer power semiconductor devices in the main branch (6 FBSMs form a 2×3 matrix, cooling system, power adapter)
- Use of a lightweight contact system (6 vacuum interrupters in series, 40.5kV because each UFD separates without experiencing current)
- Modular design (4 modular units, 50kV each, 36 FBSMs each unit), which facilitates maintenance and spare parts, and
- High reliability resulting from exposure to lower voltages due to the series design that distributes voltages during switching.

Although no relevant IEC standards currently exist, conformance tests must be performed to verify the HVDC circuit breaker design. These were developed based on the operating principles and conditions of the HVDC breaker, as well as the present VSC-HVDC valve test IEC standard. The type test was divided into two parts: the insulation test and the operating test.

The insulation test verifies the voltage withstanding capacity and the voltage-sharing characteristic of a HVDC circuit breaker. The operating test checks the capacity of each core component to withstand serious stress and the operational properties under different circumstances. Table 1 shows some of the main test items.

- **Table 1 The insulation and operating test items of HVDC circuit breaker**

No.		Test object	Items	Objective
1	Insulation	Phases to	DC voltage withstand test	To verify the voltage

2	test	ground	Switching impulse withstand test (SWT)	withstanding capacity and partial discharge level of support structure	
3			Lighting impulse withstand test (LWT)		
4		Across the open contacts	DC voltage withstand test		To verify the voltage withstanding capacity of across the open contacts
5			SWT		
6		Operating test	Key components		Peak withstand current test
7	Overload withstand current test				
8	Short-time withstand current test				
9	Short-time withstand current test				
10	Overall prototype	Overall prototype	Rated current interruption test	To verify the current interruption capacity and the interruption time of the overall prototype and the program correctness of the control and protection system	
11			Short-circuit current interruption test		
12			Rated current making test		
13			Short-circuit making test		

The 200kV hybrid DC circuit breaker successfully passed the test where a 15 kA short-circuit current was cleared within 3ms and the transient interruption voltage across the test object exceeded 320kV.

7.2 Installed Mechanical DC CB in Nan'ao multiterminal system

The Nan'ao multi-terminal HVDC project, with a ± 160 kV rated DC voltage, was completed by China Southern Power Grid (CSG) and put into operation at the end of 2013. This project includes three converter stations: Sucheng station, Jinniu station and Qing'ao station. The project collects wind power supplied to Jinniu and Qing'ao stations and sends it to the mainland. This project originally adopted the same method of using AC breakers to interrupt DC faults as utilized in the Zhoushan project, which achieved the lowest possible power losses and capital expenses but meant the project suffered from slow DC fault clearing times. The problem was upgraded in 2017 by installing three mechanical DC circuit breakers rated 160kV (See Figure 8).

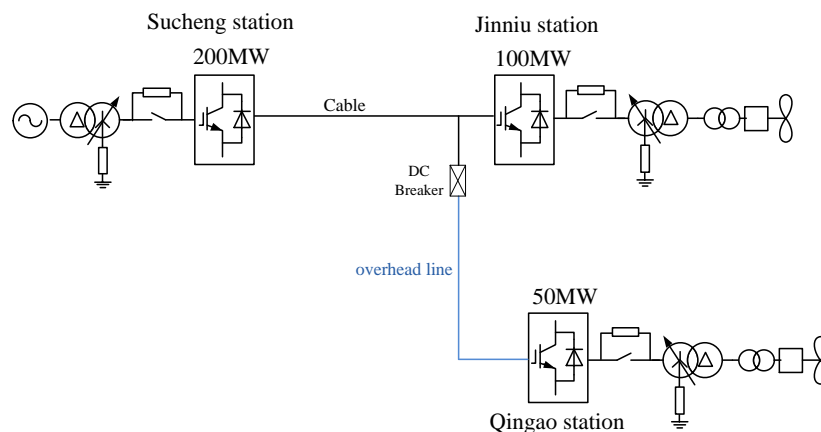

Figure 8. The Nan'ao 3-terminal HVDC transmission system with installed mechanical DC CB.

Figure 9 illustrates the topology and a picture of the installed prototype 160kV mechanical HVDC circuit breaker. It consists of the following:

- 1) The main branch consisting of four 40 kV rated DC voltage vacuum interrupters (VIs) connected in series, which satisfy requirements for meeting system voltage levels and fast response times. Adequate voltage-sharing during dynamic events and static state requirements are achieved by

arming each VI with a transient grading capacitor C_j , damping resistor R_j , and static voltage-sharing resistor R_x .

- 2) The current injection branch is divided into a high-voltage side and a low-voltage side that are completely isolated electrically through use of an air-core transformer with mutual inductance M , where the high coupling factor k allows for high energy transfer efficiencies. Air core design is the most efficient solution because of high power transfer at high frequency.
- 3) The energy absorber consists of banks of surge arrestors, directly connected to the series connection of the four VIs.

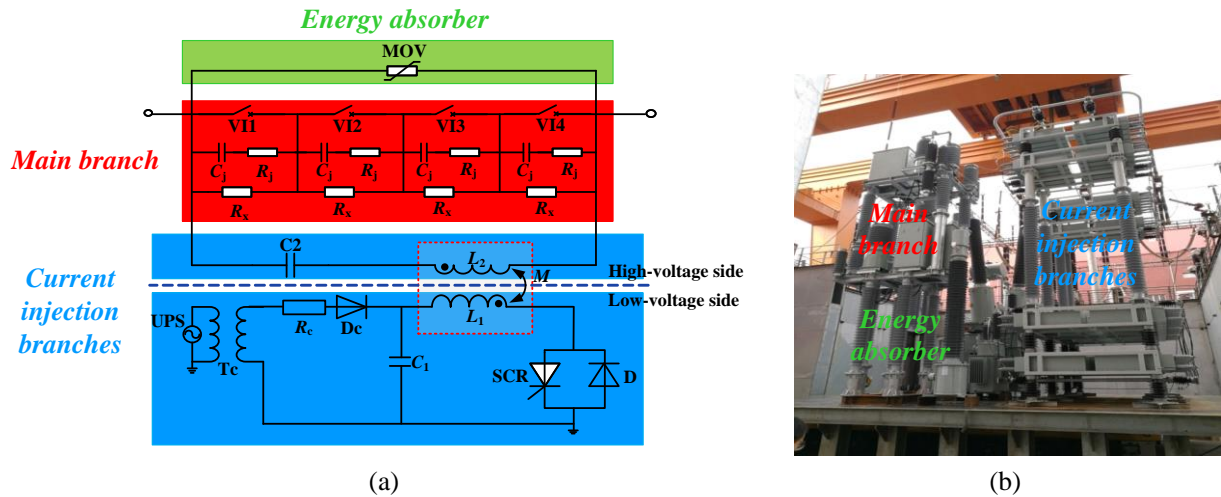

Figure 9. 160kV mechanical HVDC circuit breaker: (a) topology, and (b) prototype.

Similar to the operating principle described in Section 5, the Nan'ao mechanical HVDC CBs use a combination of an inductor and pre-charged capacitors to produce the current zero across the VIs. The difference is that the storage capacitor in this scheme is charged on the low-voltage side of the CB rather than at the high-voltage side. This technical solution charges the storage capacitor C_1 to the target voltage by introducing a UPS boost circuit. The UPS voltage is boosted by the isolation transformer T_c , and then rectified into a DC voltage through the high voltage silicon rectifier, D_c , where the resistor R_c is used to limit the inrush current during the charging process.

Compared to conventional mechanical DC circuit breakers, this mechanical HVDC circuit breaker offers advantages of reduced costs, footprint, and height that are achieved by utilizing an air-core coupling reactor and smaller size of key components appearing in the injection branch.

Experimental results show that the mechanical high-voltage DC circuit breaker successfully interrupted a 9.2kA fault current with peak of TIV reaching 272kV in 3.9 ms.

7.3 DC CB installed in Zhangbei HVDC grid

Due to its geographical advantage, the Zhangbei region of North China has seen considerable renewable wind resource development and this trend is expected to continue until 2020. However, successfully integrating these resources presents challenges resulting from their asymmetric distribution with energy consumption, and their intermittent and highly variable characteristics. Implementing HVDC facilities helps resolve many of these concerns and the availability of a viable HVDC circuit breaker makes the construction of HVDC grids feasible. As a result, a $\pm 500\text{kV}/3000\text{ MW}$ four-terminal HVDC Grid project has been proposed.

The project adopts a four-terminal ring, and the operating configuration is a bipolar topology with a metallic return line (see Figure 10). The Zhangbei and Kangbao converter stations are the sending terminals collecting local wind power. The Fengning converter station is a regulating terminal connected to a local pumped-storage hydro-plant which can smooth the output power fluctuations of the wind power resources. The Beijing converter station is the receiving terminal used to supply renewable power for Beijing.

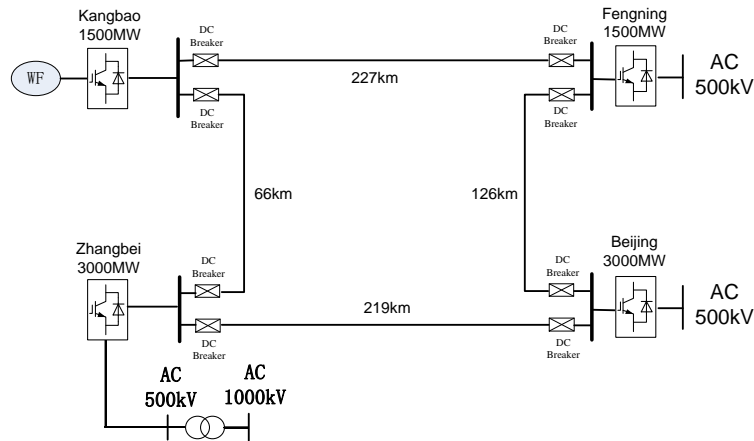

Figure 10. The Zhangbei four-terminal HVDC grid with DC CB

The Zhangbei project adopts a half-bridge modular multi converter (MMC) technology and uses overhead lines. As a result DC breakers must be configured at the both end of line to clear potential DC faults such as lightning induced faults. A 500kV DC breaker prototype was developed in 2018 and the project is scheduled for operation by 2020.

Acknowledgement

Research work is in part funded by National Key R&D Program of China (2017YFB0902400).

Biographies

Dragan Jovcic is a professor and director of Aberdeen HVDC research Centre at University of Aberdeen, UK.

Guangfu Tang is a vice president of Global Energy Interconnection Research Institute of SGCC (State Grid Corporation of China), PRC

Hui Pang is a vice director of HVDC department of Global Energy Interconnection Research Institute, PRC

For Further Reading

- [1] D Jovcic and K Ahmed "High Voltage Direct Current Transmission: Converters Systems and DC Grids", Wiley, 2015,
- [2] J. Häfner and B. Jacobson, "Proactive Hybrid HVDC Breakers - A key innovation for reliable HVDC grids," Proc. CIGRE 2011 Bologna Symp., Bologna, Italy, pp. 1-7, Sep 2012.
- [3] K. Tahata, S. Oukaili, K. Kamei, et al., "HVDC circuit breakers for HVDC grid applications," Proc. IET ACDC 2015 conference, Birmingham, UK, pp. 1-9, Feb 2015.
- [4] GuangfuTang, Zhiyuan He, Hui Pang, Xiaoming Huang, Xiaoping Zhang. "Basic topology and key devices of the five-terminal DC grid", CSEE Journal of Power And Energy Systems, Vol. 1, No. 2, pp.22-35, June 2015
- [5] Guangfu Tang, Xiaoguang Wei and Wandu Zhou, "Research and Development of a Full-bridge Cascaded Hybrid HVDC Breaker for VSC-HVDC Applications," CIGRE 2016 Session, Paris, paper A3-117, Sep.2016.
- [6] EU Horizon2020 project PROMOTioN, <https://www.promotion-offshore.net/>